

27" Undercounter Refrigerator with Drawers

MODEL: SKR27AD/C15



Silver King® is the leader in reliable and energy efficient refrigeration solutions. Our sleek, stainless steel refrigerators are made with the highest quality materials to guarantee everything is kept fresh and meets temperature standards. Our refrigerators have polyurethane insulation for maximum strength and durability, and minimal energy waste.

Standard Features

- Exterior stainless steel with galvanized back and bottom reduces risk of corrosion.
- Interior aluminum, coved corners and finished edges for easy cleaning.
- Environmentally friendly polyurethane foamed-in-place insulation for maximum strength and durability.
- Supplied with four casters (two with locks) for ease of placement.
- Standard 8 foot 3 wire power cord NEMA 5-15P plug.
- Santoprene™ gaskets last four times longer than the industry standard.
- Each drawer has a capacity of a full size 6" deep pan with several possible pan configurations for 1/9, 1/6 and 1/3 pan sizes.
- CFC-free, 134A refrigerant, hermetically sealed, high efficiency, self contained refrigeration system with automatic defrost and forced air circulation.
- Adjustable temperature control mounted in back for easy access.
- Automatic condensate evaporator means no plumbing or floor drains.
- Limited Warranty: 1-year labor, 1-year parts, 5-year compressor (part only), 90-days replacement parts. Warranty is determined by the original equipment manufacturing date for general market.*

Specifications

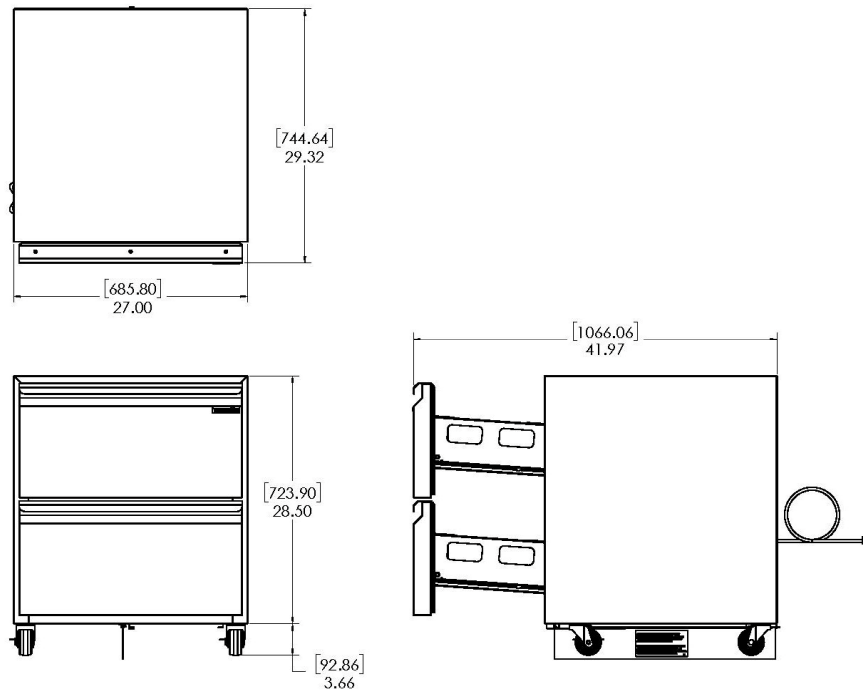

Dimensions

Model Number	Width in (mm)	Height in (mm)	Depth in (mm)	Gross Shipping Weight lb (kg)	Unit Net Weight lb (kg)	Shipping cu ft (cu m)
SKR27AD/C15	27 (685.80)	32.16 (816.76)	29.32 (744.64)	195 (88.45)	185 (83.91)	27.4 (.776)

Electrical

Model Number	Country of Origin	Amps	Voltage	Hz	Plug
SKR27AD/C15	USA	2.7	115 VAC	60 Hz	NEMA 5-15P

Certifications

